



**Electrolux**  
PROFESSIONAL

**Modular Cooking Range Line  
thermaline 90 -1000mm Passthrough  
Electric Warming Cabinet, 4 doors, GN  
conform, 2 Sides(H2)-H=450**

ITEM # \_\_\_\_\_

MODEL # \_\_\_\_\_

NAME # \_\_\_\_\_

SIS # \_\_\_\_\_

AIA # \_\_\_\_\_

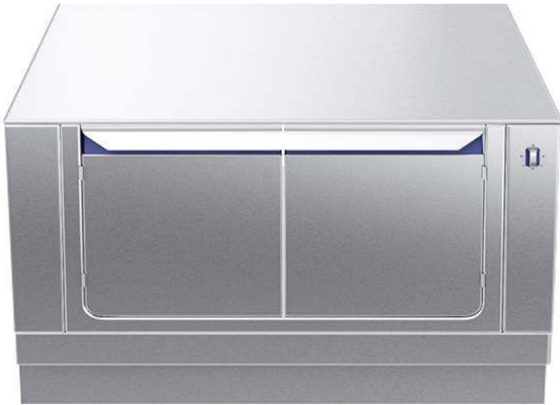

589486 (MC4KCCJOAO)

Passthrough electric warming cabinet, with 4 doors, two-side operated, GN - H2

### Short Form Specification

Item No. \_\_\_\_\_

1000 mm wide passthrough warming cabinet with 4 doors, constructed according to DIN 18860\_2 with 70 mm recessed plinth. Internal frame for heavy duty sturdiness in 2 mm and 3 mm in 1.4301 (AISI 304). 2 mm top in 1.4301 (AISI 304). Flat surface construction, easily cleanable. THERMODUL connection system enables seamless worktop when units are connected and avoids soil penetrating. Temperature in the cabinet can be set through thermostat, up to a maximum of 110 °C. Cabinet storage space accepts GN 1/1 containers.

IPX5 water resistant certification.

Configuration: Two-side operated freestanding base, hygienic class H2.

### Main Features

- All major components may be easily accessed from the front.
- THERMODUL connection system creates a seamless work top when units are connected to each other thus avoiding soil penetrating vital components and facilitating the removal of units in case of replacement or service.
- Unit constructed according to DIN 18860\_2 with 70 mm recessed plinth.
- Temperature in the cupboard can be set through a thermostat to suit different requirements. The maximum temperature is 110°C.
- Unit can be installed below modular top appliances, designed to keep plates warm.

### Construction

- IPX5 water resistance certification.
- 2 mm top in 1.4301 (AISI 304).
- Flat surface construction with minimal hidden areas to easily clean all surfaces
- Storage space in the base of the appliance accepts GN1/1 containers.
- Internal frame for heavy duty sturdiness in stainless steel.

APPROVAL: \_\_\_\_\_



Experience the Excellence  
www.electroluxprofessional.com  
ELUX\_EMAIL

Front

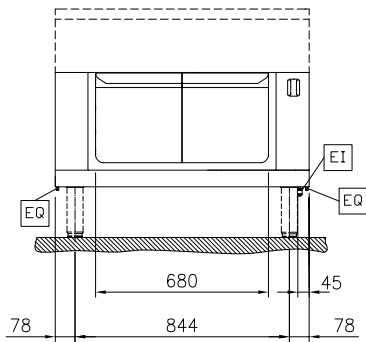

Side

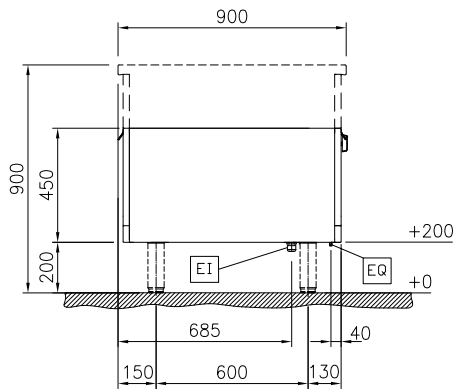

EI = Electrical inlet (power)

Top

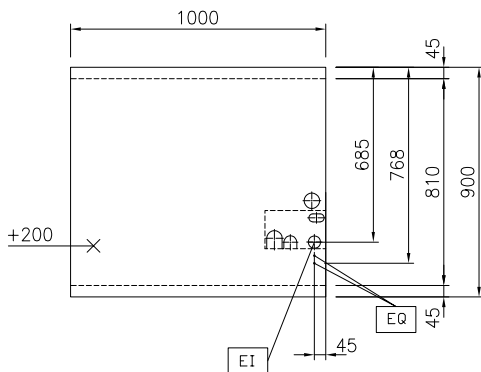
**Key Information:**

External dimensions, Width:	
589486 (MC4KCCJOAO)	1000 mm
External dimensions, Depth:	900 mm
External dimensions, Height:	450 mm
Cupboard Cavity Dimensions (width):	680 mm
Cupboard Cavity Dimensions (height):	330 mm
Cupboard Cavity Dimensions (depth):	810 mm
Cabinet temperature range:	30-110 °C
Net weight:	36 kg

**Sustainability**

Current consumption:	5 Amps
----------------------	--------

## Optional Accessories

- Stainless steel side panel, 900x700mm, freestanding PNC 912512
- Stainless steel front kicking strip, 1000mm width PNC 912636
- Stainless steel side kicking strip left and right, freestanding, 900mm width PNC 912657
- Stainless steel plinth, freestanding, 1000mm width PNC 912960
- - NOT TRANSLATED - PNC 913238
- - NOT TRANSLATED - PNC 913244
- - NOT TRANSLATED - PNC 913260
- - NOT TRANSLATED - PNC 913284
- STAINLESS STEEL DIVIDING PANEL 900X700MM LEFT/RIGHT PNC 913672
- STAINLESS STEEL SIDE COVER PANEL, FLUSH 900X700MM LEFT/RIGHT PNC 913688